



FAIRHAVEN Gazebo Panel - Fixed Louvres

ASSEMBLY GUIDE

THANK YOU FOR PURCHASING OUR FAIRHAVEN PANEL



This manual will provide you with clear and detailed instructions on how to safely and correctly assemble and maintain your gazebo, to ensure it brings you many years of use and enjoyment.

IMPORTANT: RETAIN FOR FUTURE REFERENCE: READ CAREFULLY

Warning: Important safety instructions. It is important for the safety of persons to follow these instructions. Please keep these instructions in a safe place.

This product can be used by children ages from 8 years and above and persons with reduced physical, sensory or mental capabilities or lack of experience and knowledge if they have been given supervision or instruction concerning use of the product in a safe way and understand the hazards involved. Children shall not play with the product. Cleaning and user maintenance shall not be conducted by children without supervision of an adult.

Intended use

This gazebo is intended for outdoor domestic use in residential environments, and to protect users from direct sunlight, glare and heat. Any use or modification to the gazebo not included in this manual shall be considered as improper use, which may cause considerable danger to users and property and will void the product warranty.

Attention: The schematics in this manual are for assembly and operation illustration only. They may differ from the gazebos actual appearance.

⚠ WARNING

- When assembling and using this product, safety precautions should always be followed to reduce the risk of personal injury and damage to equipment. Please read all instructions before assembly and use.
- At least two or more people are recommended for safe assembly.
- Keep all children and pets away from assembly area.
- Check all nuts and bolts for tightness before and during usage.
- Non permanent structure. Do not use in extreme weather conditions including heavy rain or high winds.
- Do not leave the gazebo unattended. Louvres must remain in the open position when not in use.
- Do not place the product near an open flame; or too close to any heat source.

Shutter wall

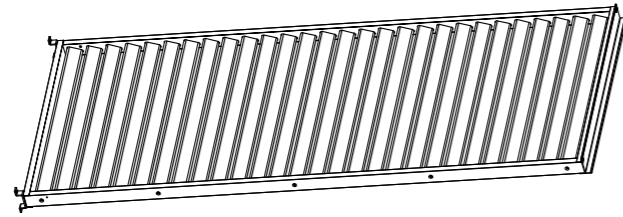

REF	PARTS	QTY	SPECS
A		1	
B		1	
C		28	
D		2	
E		4	ST5.5X50
F		4	8X40
G		2	ST4.8X38
H		2	ST4.8X25
I		11	ST4.8X30
J		1	
K		1	
L		2	
M		13	ST4.2X25

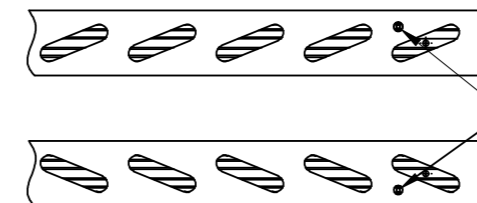
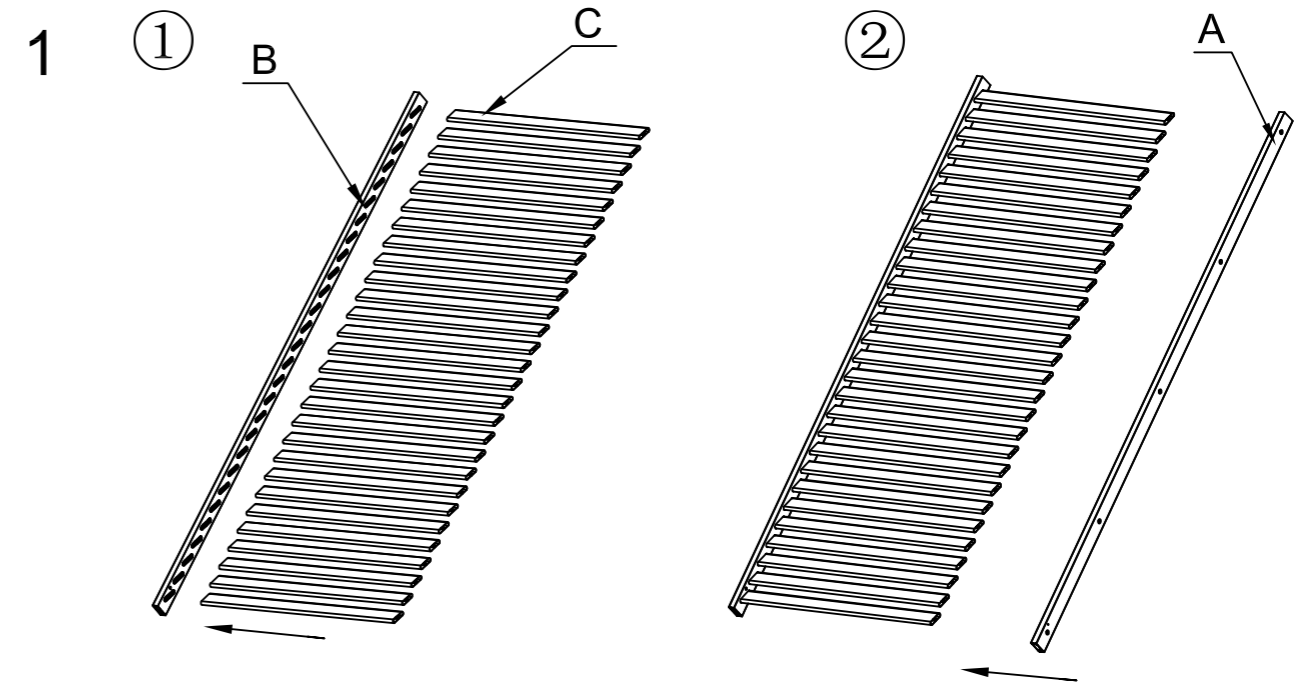

when this bar is in vertical direction, put the end with hole downwards and face outwards

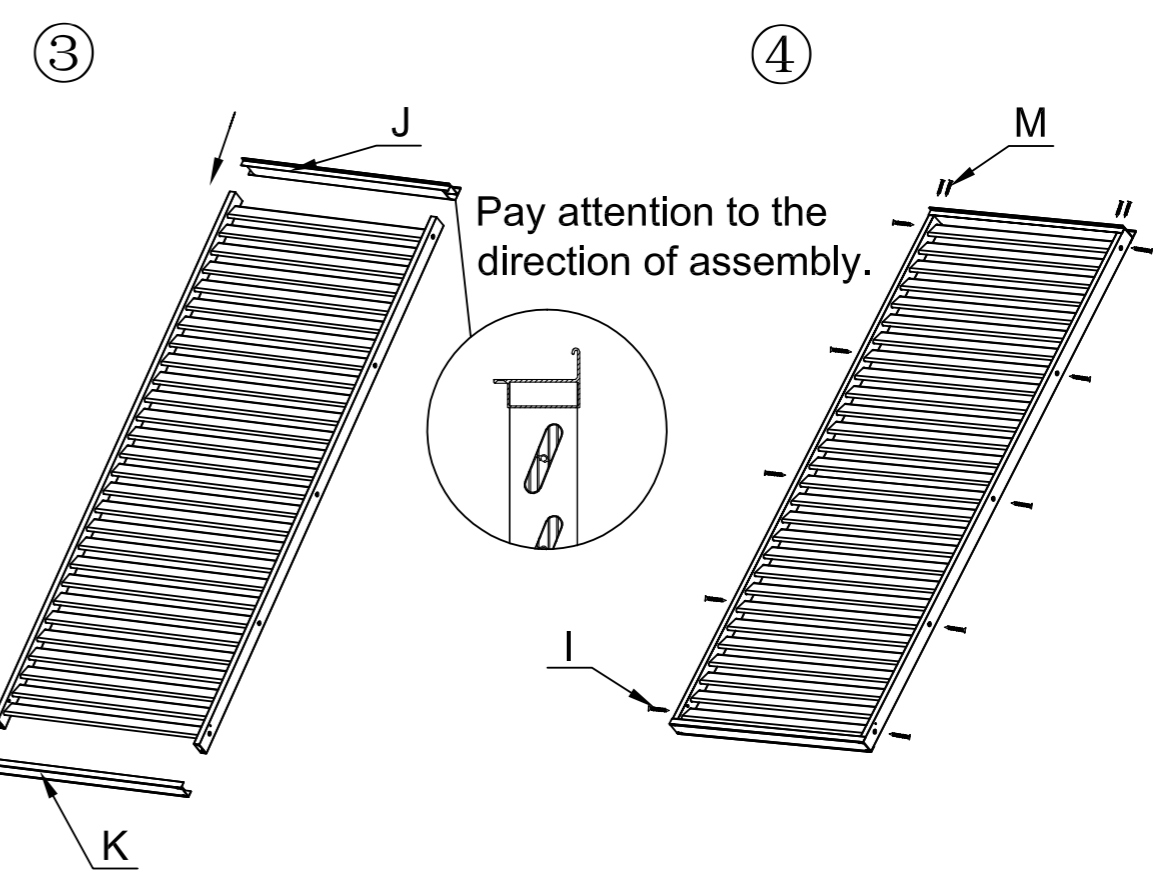

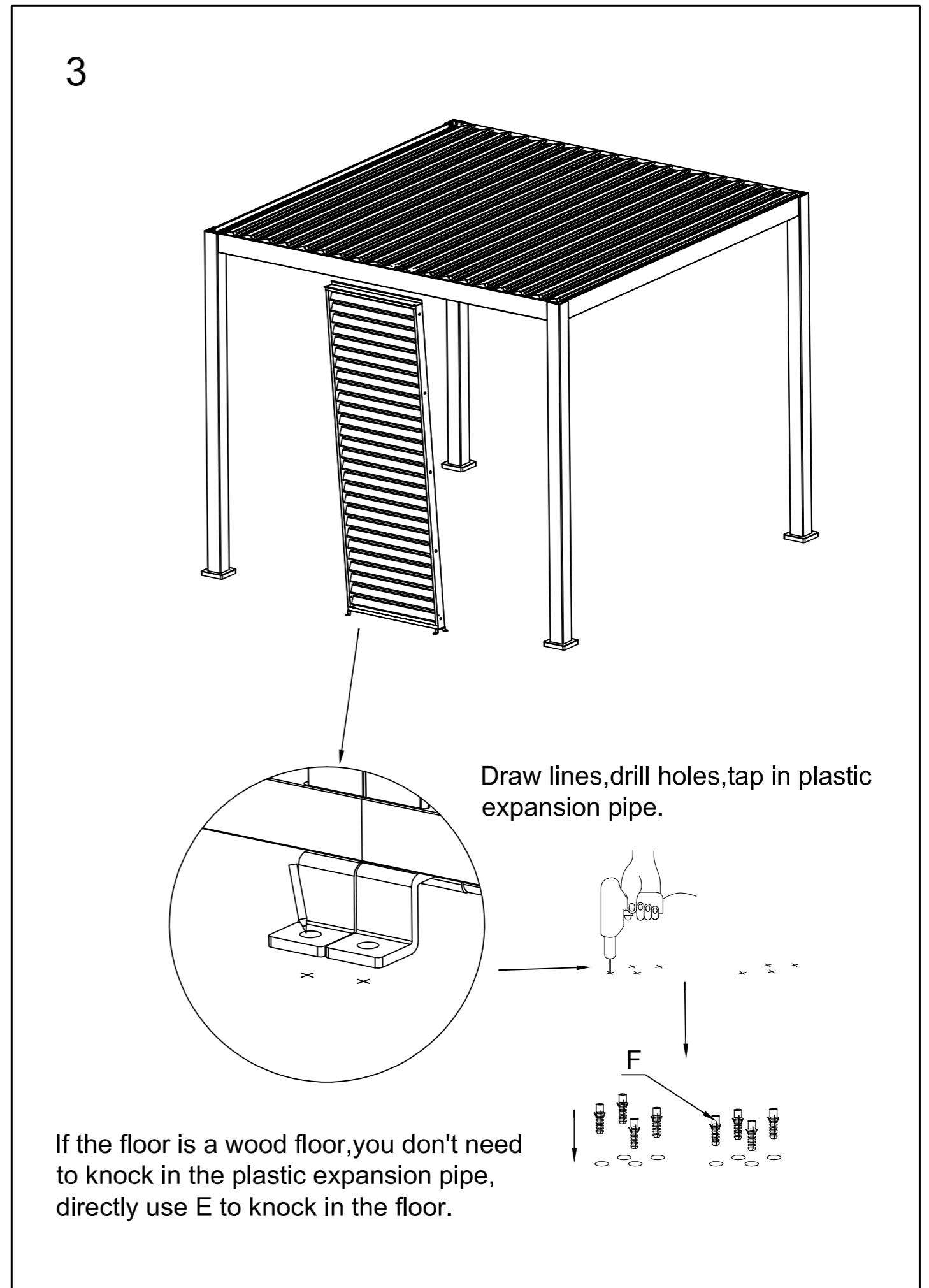
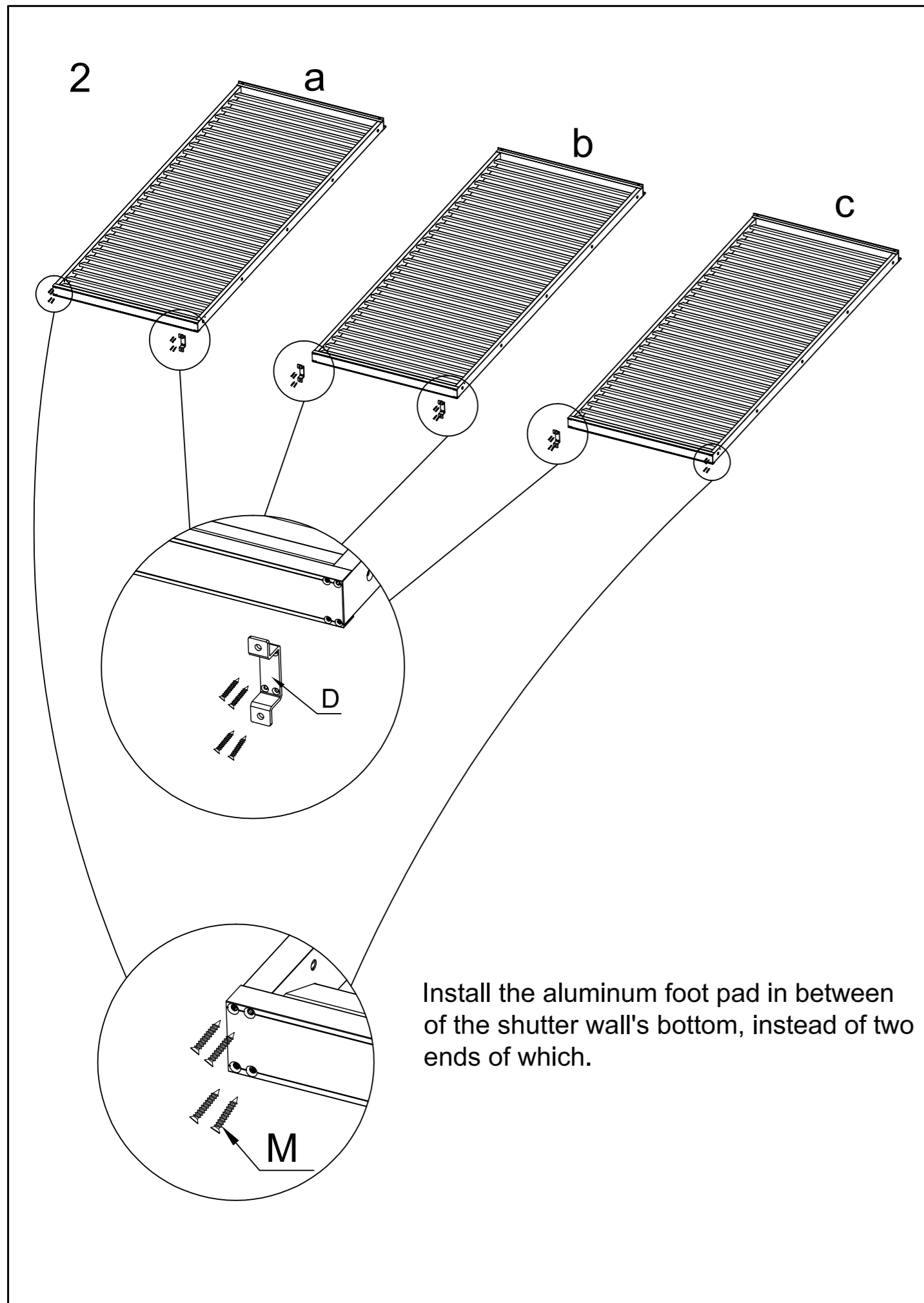

4

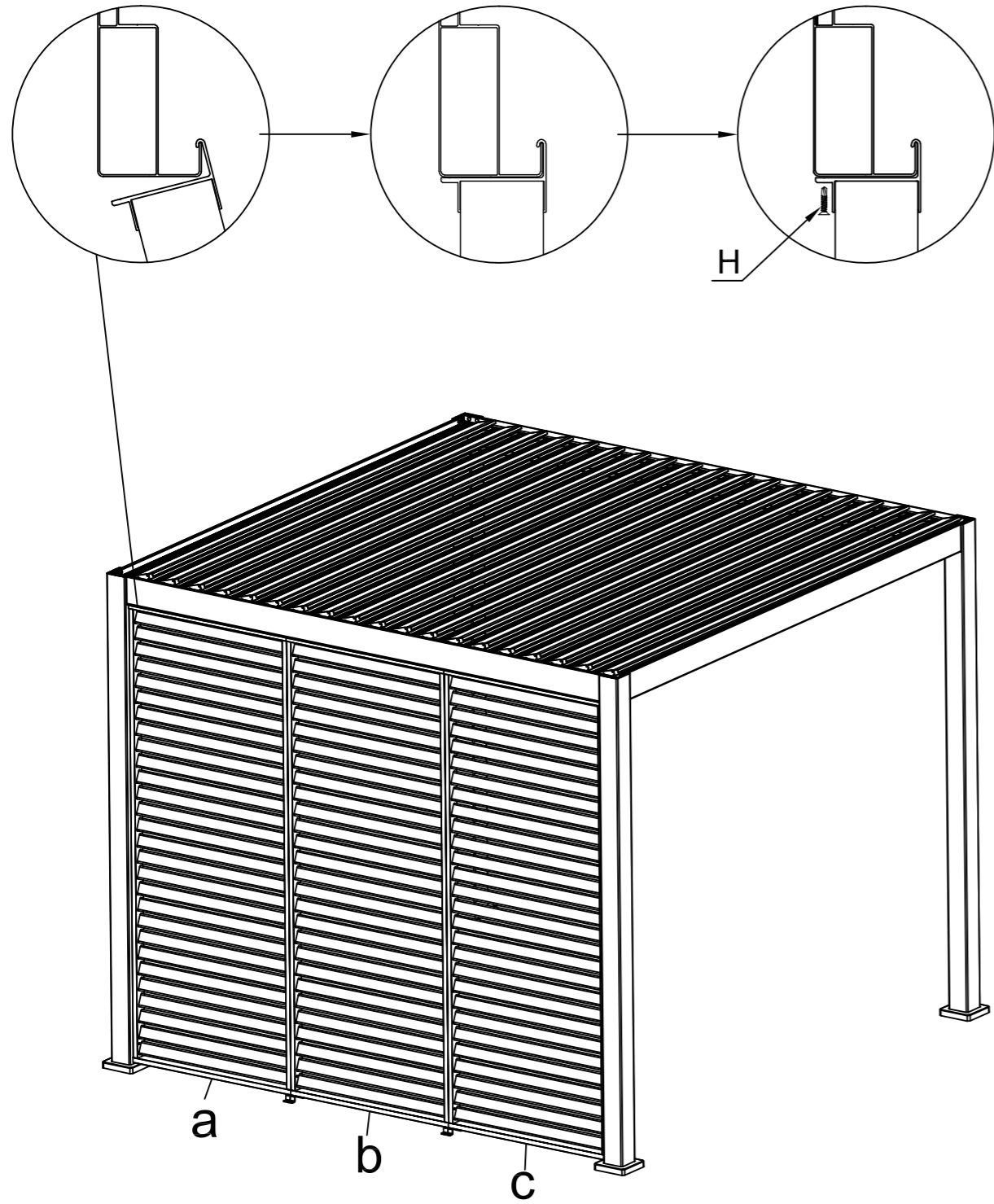

5

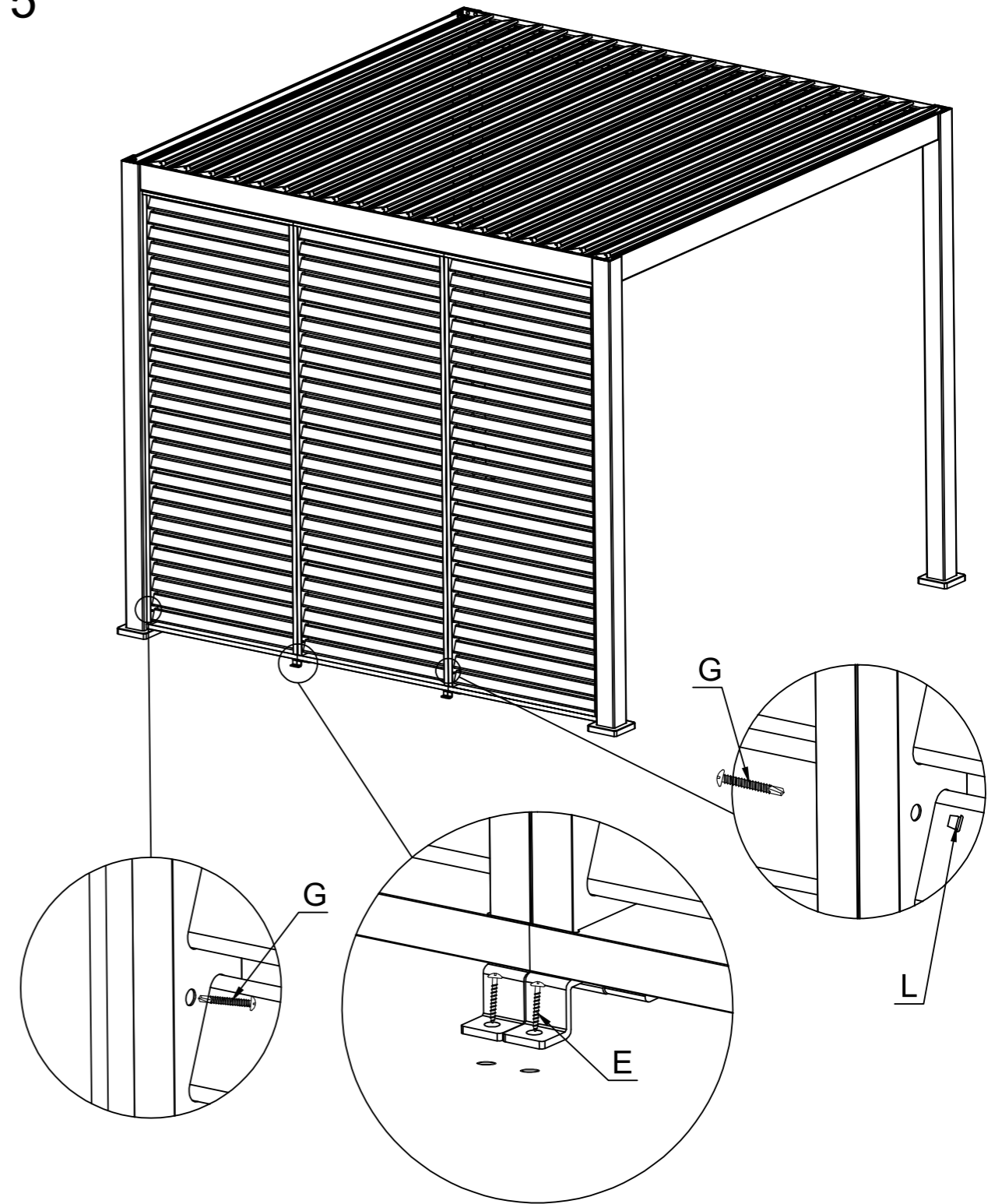

The tools you need:



Glove



Knife



Safety hat

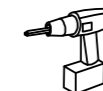

Electric screw driver



Percussion drill

PRODUCT WARRANTY & LIMITATION OF LIABILITY

Coolaroo products are manufacture by Gale Pacific Limited ACN 082 263 778 (Gale). Gale provides the following warranty in relation to Coolaroo products (“Product”).

The benefits of this warranty are in addition to any rights and remedies imposed by Australian Consumer Law, NZ Consumer Guarantees Act 1993, and state and federal legislation that cannot be excluded. Nothing in this warranty is to be interpreted as excluding, restricting or modifying any applicable legislation to the supply of goods and services which cannot be excluded, restricted or modified.

WARRANTY

Gale warrants that, subject to the exclusions and limitations below, all parts of the manufacture and assembly of the Product will be free from defects in materials and workmanship for a period of one (1) year from the date of purchase.

If a defect appears in the Product before the end of the warranty period and Gale finds the product to be defective in materials or workmanship, Gale will, in its sole discretion, either:

- a) replace or repair the Product or the defective part of the Product free of charge; or
- b) refund the purchase price of the Product.

Gale reserves the right to replace defective parts of the Product with parts and components of similar quality, grade and composition where an identical part or component is not available.

The warranty will not apply where:

- a) the Product has been altered or modified by someone other than Gale or its authorised agent;
- b) the alleged defect in the Product is within acceptable industry variances;
- c) Gale cannot establish any fault in the Product;
- d) the defect in the Product has arisen due to the customer’s failure to install and use the Product in accordance with the instructions provided;
- e) the defect in the Product has arisen due to the customer’s request to customise the Product;
- f) the Product has been subject to abnormal conditions, including environment, temperature, water, fire, humidity, pressure, stress or similar.

The warranty does not extend to:

- a) damage or defects caused by normal wear and tear,
- b) water or sun damage; or
- c) any other damage caused by the customer placing other equipment, furniture or material in close proximity to the Product.

Gale makes no express warranties or representations other than set out in this warranty.

The repair or replacement of the Product or part of the Product is the absolute limit of Gale’s liability under this express warranty.

WARRANTY CLAIMS

- 1) Upon purchasing the Product, the customer must register their warranty by completing the Coolaroo online warranty registration at www.coolaroo.com. Alternatively, the customer can contact Coolaroo Customer Service on 1800 331 521 (AU) or 0800 555 171 (NZ) for assistance.
- 2) If a fault covered by warranty occurs, the customer must contact Gale using the contact details provided.
- 3) Any warranty claim must be accompanied by proof of purchase and details of the alleged defect.
- 4) The customer must bear the cost of the transport of the Product to and from Gale or the authorised agent to make the warranty claim, and all insurance of the Product.

AUSTRALIAN CONSUMER LAW

Nothing in this agreement is intended to have the effect of contracting out of any applicable provisions of the Competition and Consumer Act 2010 or the Fair Trading Acts in each of the States and Territories of Australia, except to the extent permitted by those Acts where applicable.

This warranty is not transferable, and applies only to the initial purchaser of the installed Product.

In addition to the above warranty, Australian Consumer law and other state and territory legislation may imply warranties or conditions or impose liability on Gale in relation to the Product or its supply which cannot, or can only to a limited implied warranties or conditions and such liability, and for the warranty described above:

- a) all warranties and conditions (whether express or implied, statutory or otherwise) relating to the Product or its supply are expressly excluded; and
- b) Gale will not be liable for any loss or damage suffered by any person (including the purchaser of the Product) in any way relating to or arising from the Product or its use (including loss or damage arising from the negligence of, or contributed to by, Gale).

If liability for breach by Gale of a warranty or condition or any other liability imposed on Gale by legislation which cannot be excluded may be limited, Gale’s liability is limited to the extent permitted by law, and if liability may be limited in any one of a number of ways, Gale’s liability is limited in any one of the permitted ways chosen by Gale in its absolute discretion.

The Purchaser acknowledges that the Purchaser does not rely on the skill or judgment of Gale as to whether or not the Products are fit for any particular purpose.

The Purchaser indemnifies Gale from every liability, loss, damage, cost or expense directly or indirectly incurred or suffered by Gale caused by or contributed to by the Purchaser’s failure to:

- 1) adequately provide or display safety markings or safety information on or with the Products;
- 2) comply with any law about the Products or their use;
- 3) take any reasonable precaution to bring to the attention of any potential users of the Products any dangers associated with Products;
- 4) any negligence or breach of duty by the Purchaser or any breach by the Purchaser of these terms.



THANK YOU
FOR PURCHASING A COOLAROO PRODUCT

Exposure to ultraviolet (UV) radiation from the sun is the major cause of skin cancer. In some countries the UV radiation is strong enough to cause sunburn in just 11 minutes on a fine summers day. To prevent sun damage we recommend following the Sun Smart steps: slip on clothing, slop on sunscreen, slap on a hat, slide on sunglasses and seek shade.

To register your product go to coolaroo.com. The product code can be found printed above the barcode on the product packaging, alternatively you can find it on the relevant coolaroo.com product page.



Gale Pacific Limited
145 Woodlands Drive, Braeside,
Victoria, 3195 Australia

Australia: 1800 331 521
New Zealand: 0800 555 171

2000289

Made in China

© Coolaroo is a registered
trademark of Gale Pacific Limited

coolaroo.com

2025-12